

GALFER[®]
Brake like a PRO



***CUSTOM
CATALOGUE***

DISCS & PADS



INDEX

OUR PRODUCTS - 4

BRAKE DISCS - 6

BRAKE PADS - 12

MOTORBIKE LIST - 14

BRAKE DISCS REFERENCES - 18



*OUR
PRODUCTS*

GALFER

Brake like a PRO

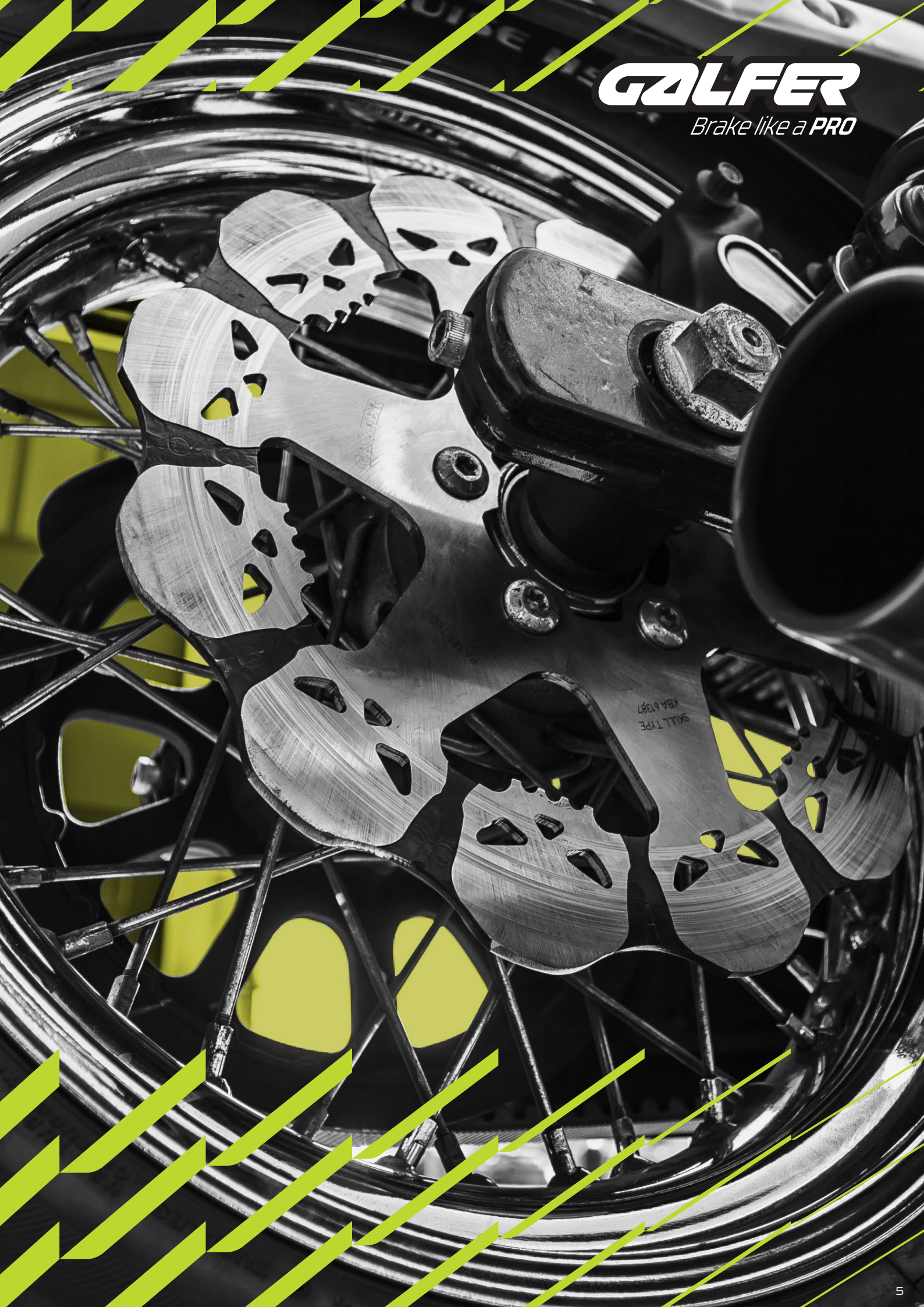

SKULL TYPE
K84.6387

BRAKE DISCS

Classic **THE ROUND**

REF
V



REF
FLV

Galfer round discs are the most classic in terms of their appearance, they are the perfect replacement to maintain the original aesthetics, and they are characterized by excellent corrosion resistance. They are made of high-carbon stainless steel, and in the case of the floating ones, the core is stainless steel (AISI 420).

Los discos Galfer redondos son los más clásicos en cuanto a su apariencia, son el recambio perfecto para mantener la estética original y se caracterizan por una excelente resistencia a la corrosión. Están fabricados en acero inoxidable de alto contenido en carbono y, en el caso de los flotantes, el núcleo es de acero inoxidable (AISI 420).

I dischi Galfer rotondi sono i più classici per quanto riguarda la loro estetica, sono la perfetta sostituzione per mantenere l'estetica originale e si caratterizzano per un'eccellente resistenza alla corrosione. Sono realizzati in acciaio inossidabile ad alto tenore di carbonio e, nel caso dei dischi flottanti, il nucleo è in acciaio inossidabile (AISI 420).



BRAKE DISCS

Disc Wave®

THE GENUINE

REF
W



REF
FLW/CW

Galfer Disc Wave® discs are the most popular on the catalog. Thanks to their larger brake track perimeter, they enhance cooling capacity and allow for even wear of the brake pads. They undergo a cathodic electrocoating treatment to prevent corrosion. In the case of floating discs, they offer an improvement in weight reduction, and there are two variants: those with a high-strength anodized aluminum center (7075 T6 - 6082 T6) and those with a steel core (AISI 420).

Los discos Galfer Disc Wave® son los más populares del catálogo. Gracias a su mayor perímetro en la pista de freno aumenta su capacidad de refrigeración y permite un desgaste uniforme de las pastillas. Reciben un tratamiento de cataforesis para evitar la corrosión. En el caso de los discos flotantes, ofrecen una mejora en cuanto a la reducción de peso y existen dos variantes: aquellos con un centro de aluminio anodizado de alta resistencia (7075 T6 - 6082 T6) y aquellos con núcleo de acero (AISI 420).

I dischi Galfer Disc Wave® sono i più popolari nel catalogo. Grazie al loro maggiore perimetro sulla pista del freno, migliorano la capacità di raffreddamento e consentono un'usura uniforme delle pastiglie dei freni. Vengono sottoposti a un trattamento di elettrodeposizione catodica per prevenire la corrosione. Nel caso dei dischi flottanti, offrono un miglioramento nella riduzione del peso e ci sono due varianti: quelli con un centro in alluminio anodizzato ad alta resistenza (7075 T6 - 6082 T6) e quelli con un nucleo in acciaio (AISI 420).



BRAKE DISCS



SKULL

THE RADIKAL

REF
RH

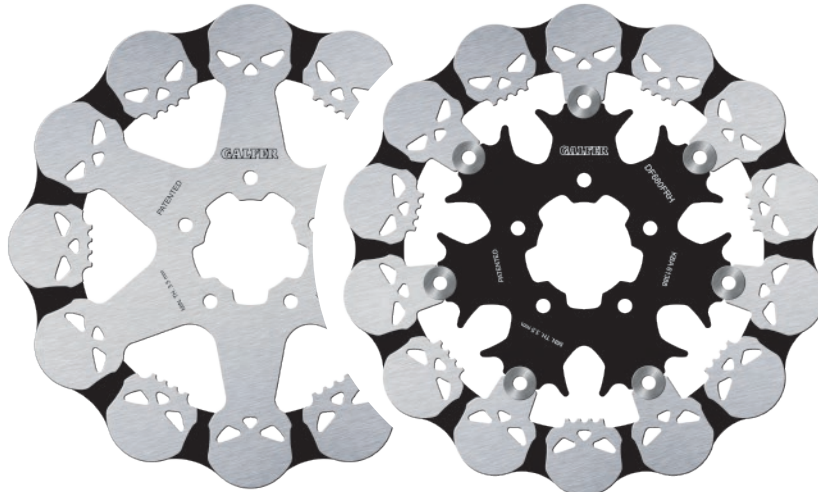

REF
FRH

Galfer Skull discs are of original design and feature custom skull motifs. They are designed for those who want to take the aesthetics of their customized motorcycle to the most extreme level. Available in a floating version, like their other variants, they come with an anti-corrosion treatment and are made of stainless steel (AISI 420).

Los discos Galfer Skull son de diseño propio y están personalizados con motivos de calaveras. Están diseñados para aquellos que desean llevar la estética de su moto personalizada al extremo más radical. Disponibles en versión flotante, al igual que sus otras versiones, cuentan con un tratamiento anticorrosión y están fabricados en acero inoxidable (AISI 420).

I dischi Galfer rotondi sono di design originale e presentano motivi personalizzati a forma di teschi. Sono progettati per coloro che desiderano portare l'estetica della propria moto personalizzata al livello più estremo. Disponibili in una versione flottante, come le altre varianti, sono dotati di un trattamento anticorrosione e sono realizzati in acciaio inossidabile (AISI 420).



BRAKE DISCS

CUBIQ® THE LIGHTEST

REF
Q

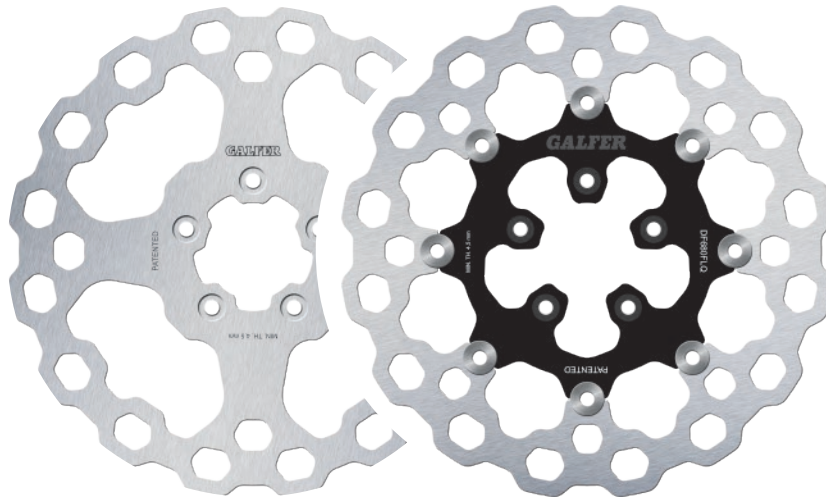

REF
FLQ

Galfer Cubiq® discs are the lightest discs in the entire range, achieving a reduction of up to 40% compared to the original discs. They enhance cooling and ensure even wear of the brake pads, positioning themselves as the most "high tech" discs in the custom category. The floating version features a stainless steel core (AISI 420). Both have cathodic electrocoating treatment to prevent corrosion.

Los discos Galfer Cubiq® son los discos más ligeros de toda la gama, logrando una reducción de hasta un 40% respecto a los discos originales. Mejoran la refrigeración y aseguran un desgaste uniforme de las pastillas, posicionándose como los discos más "high tech" en la categoría custom. La versión flotante contiene un núcleo de acero inoxidable (AISI 420). Ambos cuentan con el tratamiento de cataforesis para evitar la corrosión.

I dischi Galfer rotondi sono i dischi più leggeri dell'intera gamma, raggiungendo una riduzione fino al 40% rispetto ai dischi originali. Migliorano il raffreddamento e assicurano un'usura uniforme delle pastiglie dei freni, posizionandosi come i dischi più "high tech" nella categoria personalizzata. La versione flottante presenta un nucleo in acciaio inossidabile (AISI 420). Entrambi sono sottoposti a un trattamento di elettrodeposizione catodica per prevenire la corrosione.



BRAKE DISCS

NEW DISC WAVE®: COLOUR DISCS FOR THE CUSTOM WORLD

Galfer is launching its new Disc Wave® discs in six eye-catching colour finishes (red, blue, gold, orange, gloss black and CNC contrasting black) designed for fans of V-Twin custom motorcycles (Harley Davidson) who want to enhance the aesthetics and improve their bikes' braking performance.

The innovative GALFER DISC WAVE® coloured discs have undergone innovative colour anodizing treatment applied to the 7075 T6 aluminium centre, which not only gives them a distinctive appearance but also improves their visibility. The six eye-catching finishes (red, blue, gold, orange, gloss black and contrasting black) allow fans to personalize their bikes down to the smallest detail. Whether by combining the disc brakes with the colour of the motorcycle or improving the details, this new range of colours offers infinite possibilities to enhance the motorcycle's general appearance.

Designed to exceed the expectations of the most demanding bikers, Galfer Disc Wave® discs offer precise and efficient braking and a significant weight saving which means increased safety and control on the road.

Galfer lanza al mercado sus nuevos "Disc Wave®" en seis llamativos acabados de color rojo, azul, dorado, naranja, negro brillante y negro en contraste, dedicado a los amantes de las motos custom V-Twin (Harley Davidson) que quieren potenciar la estética y mejorar las prestaciones de frenada de sus motos.

Los innovadores "GALFER COLORED DISC WAVE®" cuentan con un avanzado tratamiento de anodizado de color aplicado al núcleo de aluminio 7075 T6 que no sólo les confiere un aspecto distintivo, sino que también mejora su visibilidad. Los seis llamativos acabados, en rojo, azul, dorado, naranja, negro brillante y negro en contraste CNC, permiten a los aficionados personalizar su motocicleta hasta el más mínimo detalle. Ya sea combinando los discos de freno con el color de la motocicleta o mejorando los detalles, esta nueva gama de colores ofrece infinitas posibilidades para elevar la estética general de la motocicleta.

Diseñados para superar las expectativas de los moteros más exigentes, los discos Galfer Disc Wave® ofrecen una frenada precisa y precisa y eficiente y un ahorro de peso importante que se traduce en mayor seguridad y control en la carretera.

Galfer lancia sul mercato i suoi nuovi "Disc Wave®" in sei accattivanti finiture cromatiche, rosso, blu, oro, oro, arancione, nero lucido e nero a contrasto, dedicati agli appassionati di moto custom V-Twin (Harley Davidson) che vogliono esaltare l'estetica e migliorare le prestazioni di frenata delle loro moto.

Gli innovativi "GALFER COLORED DISC WAVE®" vantano di un innovativo trattamento di anodizzazione del colore applicato all'anima in alluminio 7075 T6 che non solo conferisce loro un aspetto distintivo, ma ne migliora anche la visibilità. Le sei accattivanti finiture, in rosso, blu, oro, arancio, nero lucido e nero a contrasto CNC, consentono agli appassionati di personalizzare la propria moto nei minimi dettagli. Che si tratti di abbinare i dischi freno al colore della moto o di esaltarne i dettagli, questa nuova gamma di colori offre infinite possibilità di elevare l'estetica complessiva della moto.

Progettati per superare le aspettative dei motociclisti più esigenti, i dischi Galfer "Disc Wave®" offrono una frenata precisa ed efficiente e un significativo risparmio di peso che si traduce in una maggiore sicurezza e controllo sulla strada.

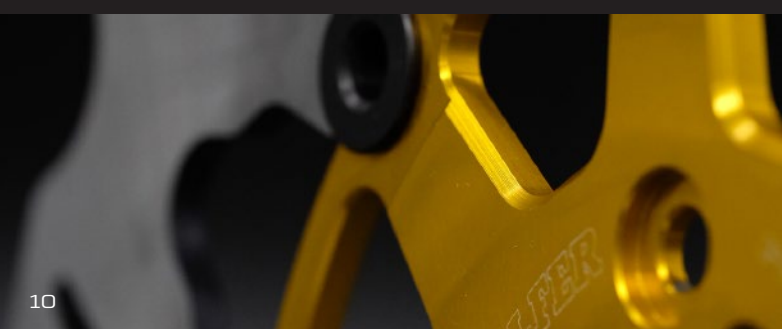
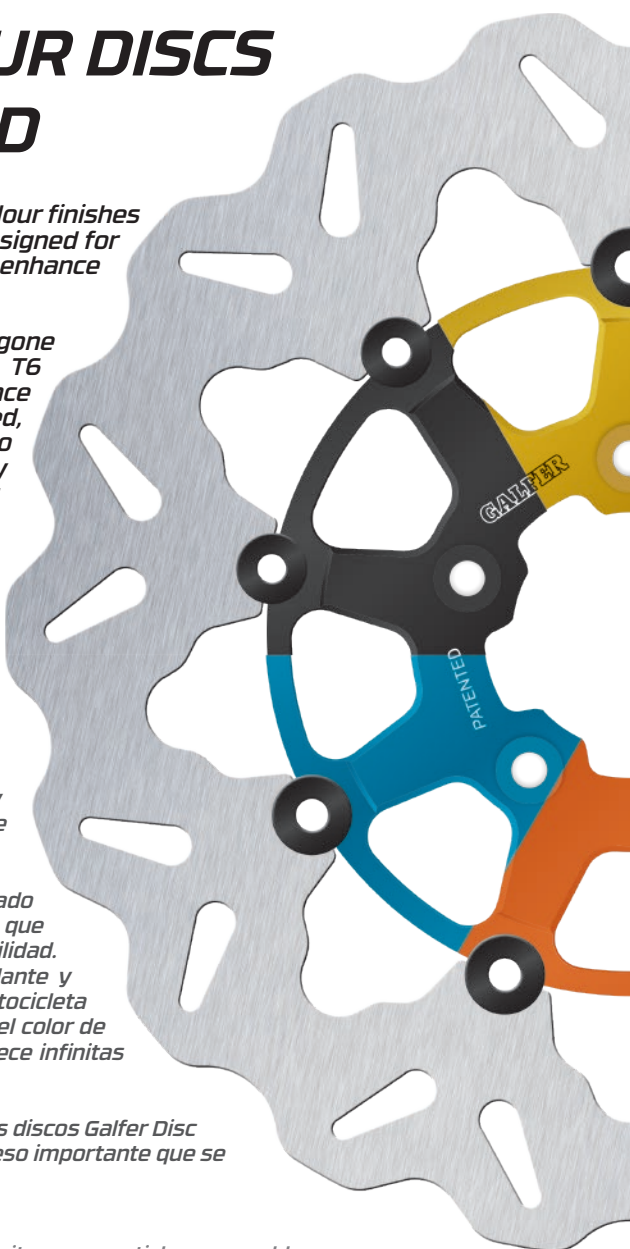

BRAKE DISCS

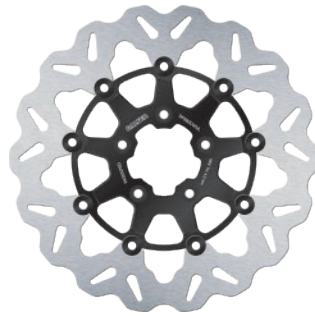

DF*CWUC**
Gloss black / Negro brillo /
Nero lucido

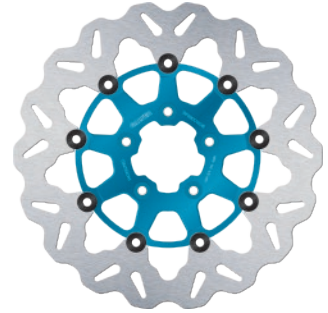

DF*CWUB**
Bule / Azul / Blu

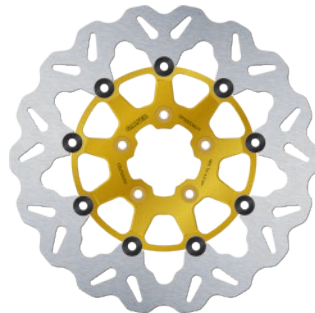

DF*CWUY**
Gold / Dorado / Oro

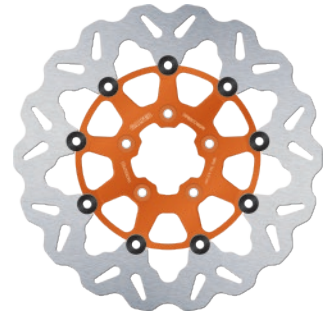

DF*CWUN**
Orange / Naranja /
Arancione

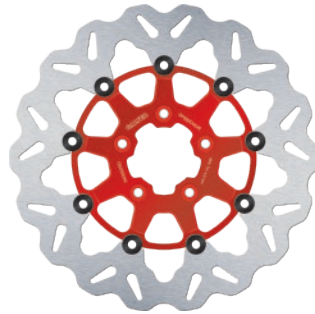

DF*CWUR**
Red / Rojo / Rosso

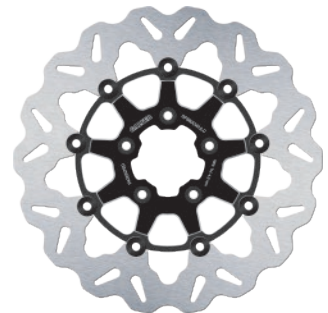

DF*CWUCL**
Contrasting black / Negro en
contraste / Nero a contrasto



★ CUSTOMIZE IT ★

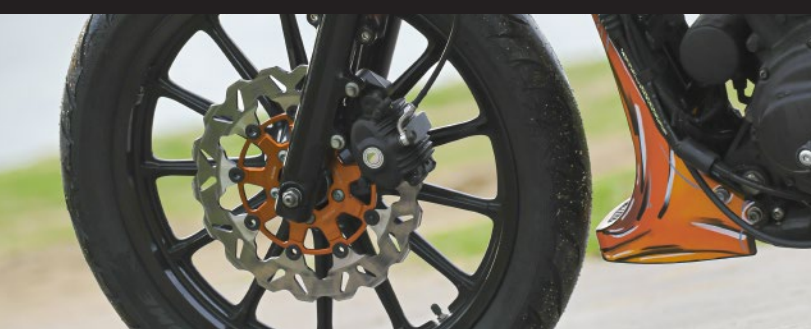

BRAKE PADS



G1054 - SEMI METAL ^(E₉) 90R

This compound embodies the past, present and future of semi-metallic production at GALFER. It has been manufactured for years with minor improvements, and it's still used today in several OE plants. The G1054 has an excellent coefficient of friction and low wear, offering progressive and effective braking. All these features make the compound suitable for all kinds of motorcycle.

Este compuesto representa el pasado, el presente y el futuro de la producción semimetálica en GALFER. Ha sido producida durante años con pequeñas mejoras y hoy en día aún la utilizan muchas plantas de OE.

Su excelente coeficiente de fricción, su bajo desgaste y su frenada progresiva y efectiva hacen que el G1054 sea un compuesto adecuado para los recambios de cualquier tipo de motocicleta.

Questa mescola rappresenta il passato, il presente ed il futuro della produzione semimetallica in GALFER. Da anni si produce questa mescola, sempre con piccoli miglioramenti, ed ancora oggi viene usata in vari impianti originali OE. Ottimo coefficiente di attrito, consumi contenuti, frenata progressiva ed efficace, tutte queste caratteristiche fanno della G1054 una mescola adatta al ricambio di ogni tipo di motociclo.



G1370/71 - SINTER STREET ^(E₉) 90R

Designed for road bike customers, G1370 is GALFER's OE product replacement. G1370 guarantees safe braking and is able to stand high temperatures without fade. Performance is not effected by adverse weather conditions. Combines safe and progressive braking with a competitive price.

Creada para satisfacer a los clientes de motocicletas de carretera, un recambio a la altura del producto original. Garantiza una frenada segura, no tiene problemas con las altas temperaturas (FADE) y en condiciones climáticas adversas no altera su rendimiento. Combina una frenada segura y progresiva con un precio competitivo.

G1370 creata per soddisfare la clientela che usa moto stradale, un ricambio che non teme paragoni con il prodotto originale. Garantisce una frenata sempre pronta e sicura, non teme le alte temperature d'uso (FADE) e non altera le sue prestazioni in condizioni atmosferiche avverse. Abbina una frenata sicura e progressiva ad un prezzo competitivo.



G1375 - SINTER SPORT ^(E₉) 90R

An upgrade of G1370 designed to satisfy the most demanding customers who, besides the usual urban use, have a taste for sport riding. This compound has a high coefficient of friction and ensures excellent performance even at high temperatures. G1375 offers adjustable and safe braking under all conditions.

Una mejora de la G1370, diseñada para satisfacer a los clientes más exigentes que, además del uso urbano habitual, desean una conducción más deportiva. Este compuesto, con un alto coeficiente de fricción, garantiza un rendimiento excelente incluso con altas temperaturas de uso. La G1375 ofrece una frenada modulable y segura en todo tipo de condiciones.

Un upgrade della nostra G1370 studiata per soddisfare la clientela più esigente che oltre all'uso normale cittadino vuole usare il proprio mezzo in maniera più sportiva. Questa mescola dall'elevato coefficiente di attrito, garantisce prestazioni eccellenti fino alle più alte temperature d'uso. Frenata modulabile e sicura in ogni condizione sono la caratteristica principale della G1375.

MOTORCYCLES LIST



MOTORCYCLES LIST

MARCA	MODELO	CC	FROM	TO	FD FRONT	COMP	Nº	DF FRONT	FD REAR	COMP	DF REAR
HARLEY D.	XG 500 STREET	500	16	20	FD172	G1054	1	DF680	FD138	G1054	
HARLEY D.	XG 750 STREET	750	16	20	FD172	G1054	1	DF680	FD138	G1054	DF724
HARLEY D.	XL883N IRON 883	883	22	22	FD344	G1054		DF835	FD267	G1371	DF724
HARLEY D.	XL1200C 1200 CUSTOM LIMITED	1200	17	17				DF835			
HARLEY D.	XL1200C 1200 CUSTOM LIMITED	1200	18	18	FD344	G1054			FD267	G1371	DF724
HARLEY D.	XL1200CX 1200 ROADSTER	1200	16	20	FD344	G1054		DF835	FD267	G1371	DF724
HARLEY D.	XL1200NS IRON 1200	1200	18	21	FD344	G1054		DF835	FD267	G1371	DF724
HARLEY D.	XL1200XANX FORTY-EIGHT ANNIVERSARY	1200	18	18	FD344	G1054		DF835	FD267	G1371	DF724
HARLEY D.	XL1200XS FORTY-EIGHT SPECIAL	1200	18	20	FD344	G1054		DF835	FD267	G1371	DF724
HARLEY D.	PAN AMERICA	1250	21		FD475	G1375	2		FD165	G1371	
HARLEY D.	RA1250S PAN AMERICA SPECIAL (LACED WHEEL)	1250	21	23	FD475	G1370		DF680	FD165	G1371	
HARLEY D.	RH 1250 SPORSTER S	1250	22		FD475	G1375	1	DF995	FD		DF996
HARLEY D.	RH1250S SPORTSTER S	1250	21	23	FD475	G1370		DF995			DF996
HARLEY D.	FLHR ROAD KING	1340	16	19			2				DF836
HARLEY D.	FLHR ROAD KING (W/AGITATOR WHEELS)	1340	16	18			2				DF836
HARLEY D.	FLHRXS ROAD KING SPECIAL	1340	17	19			2				DF836
HARLEY D.	FLHTC ELECTRA GLIDE CLASSIC (W/AGITATOR WHEELS)	1340	18	18			2				DF836
HARLEY D.	FLHX STREET GLIDE ANNIVERSARY	1340	18	18			2				DF836
HARLEY D.	CVO ROAD GLIDE (W CHISEL/SLICER WHEELS)	1450	15	15			2				DF836
HARLEY D.	FLHTC ELECTRA GLIDE CLASSIC (W/AGITATOR WHEELS)	1450	18	18			2	DF834			
HARLEY D.	FLHTCUL ELECTRA GLIDE ULTRA CLASSIC LOW	1450	15	16			2				DF836
HARLEY D.	FLHTK ELECTRA GLIDE ULTRA LTD	1450	15	18			2				DF836
HARLEY D.	FLHTK ELECTRA GLIDE ULTRA LTD (W/AGITATOR WHEELS)	1450	18	18			2				DF836
HARLEY D.	FLHTKL ELECTRA GLIDE ULTRA LTD LOW	1450	15	18			2				DF836
HARLEY D.	FLHTKSE ELECTRA GLIDE ULTRA LTD CVO ANNIVERSARY	1450	18	18			2				DF836
HARLEY D.	FLHTP ELECTRA GLIDE STD. POLICE (W/AGITATOR WHEELS)	1450	18	18			2	DF834			DF836
HARLEY D.	FLHX STREET GLIDE (W/AGITATOR WHEELS)	1450	16	16			2	DF834			
HARLEY D.	FLSS SOFTAIL SLIM S	1450	16	17			2				DF681
HARLEY D.	FLSTC HERITAGE CLASSIC SOFTAIL	1450	15		FD219	G1370	1	DF835	FD406	G1371	DF681
HARLEY D.	FLSTC HERITAGE SOFTAIL CLASSIC	1450	15	17			2				DF681
HARLEY D.	FLSTF FAT BOY	1450	15	17			2				DF681
HARLEY D.	FLSTF FAT BOY	1450	16		FD219	G1370	1	DF835	FD406	G1371	DF681
HARLEY D.	FLSTFB FAT BOY LO SOFTAIL	1450	15	15			2				DF681
HARLEY D.	FLSTFBS FAT BOYS	1450	16	17			2				DF681
HARLEY D.	FLSTN SOFTAIL NOSTALGIA	1450	15	17			2				DF681
HARLEY D.	FLSTN/i SOFTAIL DE LUXE	1450	15		FD405	G1370	1	DF835	FD406	G1371	DF681
HARLEY D.	FLTRU ROAD GLIDE ULTRA	1450	16	18			2				DF836
HARLEY D.	FLTRX ROAD GLIDE (W/AGITATOR WHEELS)	1450	15	15			2	DF834			DF836
HARLEY D.	FLTRX ROAD GLIDE CUSTOM	1450	16	17			2				DF836
HARLEY D.	FLTRXS ROAD GLIDE SPECIAL	1450	15	18			2				DF836
HARLEY D.	FLTRXSE ROAD GLIDE CUSTOM CVO	1450	18	18			2				DF836
HARLEY D.	FXDLS DYNA LOW RIDER S	1450	15	17							DF681
HARLEY D.	FXFB FAT BOB	1450	18	18							DF681
HARLEY D.	FXSB BREAKOUT	1450	15	16							DF681
HARLEY D.	FXSB BREAKOUT	1450	17	17							DF681
HARLEY D.	FXST SOFTAIL STANDARD	1450	15	15							DF681
HARLEY D.	FXST/i SOFTAIL STANDARD	1450	15		FD219	G1370	1	DF835	FD406	G1371	DF681
HARLEY D.	FXDBB DYNA STREET BOB	1573	15	15	FD405	G1370	2	DF680	FD406	G1371	DF681
HARLEY D.	FXDBC DYNA STREET BOB LIMITED	1573	15	16	FD405	G1370	2	DF821	FD406	G1371	DF681
HARLEY D.	FLS SOFTAIL SLIM	1584	15		FD219	G1370	1	DF835	FD406	G1371	DF681
HARLEY D.	FLSTFB 103 FAT BOY LO	1682	15	15			2		FD406	G1371	
HARLEY D.	FLSTN DELUXE	1682	15	17			2		FD406	G1371	
HARLEY D.	FXSB BREAKOUT	1682	15	17					FD406	G1371	
HARLEY D.	FLHR ROAD KING	1687	15	15	FD369	G1370	2	DF838	FD369	G1370	DF836
HARLEY D.	FLHR ROAD KING	1687	16	16	FD369	G1370	2	DF838	FD369	G1370	DF681
HARLEY D.	FLHR ROAD KING (W/AGITATOR WHEELS)	1687	15	15			2				DF836
HARLEY D.	FLHRC ROAD KING CLASSIC	1687	15	15	FD369	G1370	2	DF680	FD369	G1370	DF836
HARLEY D.	FLHRC ROAD KING CLASSIC	1687	16	16	FD369	G1370	2	DF680	FD369	G1370	DF681
HARLEY D.	FLHTCU ELECTRA GLIDE ULTRA CLASSIC	1687	15	15	FD369	G1370	2	DF838	FD369	G1370	DF681
HARLEY D.	FLHTCU ULTRA CLASSIC	1687	16	16	FD369	G1370	2	DF838	FD369	G1370	DF681
HARLEY D.	FLHTCUL TC ULTRA CLASSIC LOW TWIN-COOLED	1687	15	16	FD369	G1370	2	DF838	FD369	G1370	DF681
HARLEY D.	FLHTCUL ULTRA CLASSIC LOW	1687	15	16	FD369	G1370	2	DF838	FD369	G1370	DF681
HARLEY D.	FLHTK ULTRA LIMITED	1687	16	16			2	DF838	FD369	G1370	DF681
HARLEY D.	FLHTKL ULTRA LIMITED LOW	1687	15	16	FD369	G1370	2	DF838	FD369	G1370	DF681
HARLEY D.	FLRT FREEEWHEELER TRIKE	1687	15	16	FD369	G1370	2	DF835			

FD front FD rear Brake pads reference Front-Rear Comp. Brake pads compound DF front DFrear Brake disc reference Front-Rear Nº Front brake discs quantity

MOTORCYCLES LIST

MARCA	MODELO	CC	FROM	TO	FD FRONT	COMP	Nº	DF FRONT	FD REAR	COMP	DF REAR
HARLEY D.	FLS SLIM	1687	15	17	FD219	G1370	2	DF680	FD406	G1371	DF681
HARLEY D.	FLSTC 103 HERITAGE CLASSIC	1687	15	15	FD219	G1370	2	DF680	FD406	G1371	DF681
HARLEY D.	FLSTC HERITAGE CLASSIC	1687	15	17	FD219	G1370	2	DF680	FD406	G1371	DF681
HARLEY D.	FLSTF 103 FAT BOY	1687	15	15	FD219	G1370	2	DF680			DF681
HARLEY D.	FLSTF FAT BOY	1687	15	17	FD219	G1370	2	DF680			DF681
HARLEY D.	FLSTFB 103 FAT BOY LO	1687	15	15	FD219	G1370	2	DF680			DF681
HARLEY D.	FLSTFB FAT BOY LO	1687	15	17	FD219	G1370	2	DF680			DF681
HARLEY D.	FLSTN 103 DELUXE	1687	15	15	FD219	G1370	2	DF680	FD406	G1371	DF681
HARLEY D.	FLSTN DELUXE	1687	15	17	FD219	G1370	2	DF680			DF681
HARLEY D.	FLTRX ROAD GLIDE	1687	15	16	FD369	G1370	2	DF838	FD369	G1370	DF681
HARLEY D.	FLTRXS ROAD GLIDE SPECIAL	1687	15	16	FD369	G1370	2	DF838	FD369	G1370	DF681
HARLEY D.	FXDBC 103 DYNA STREET BOB LIMITED	1687	15	16	FD405	G1370	2	DF680	FD406	G1371	DF681
HARLEY D.	FXDL DYNA LOW RIDER	1687	15	17	FD405	G1370	2	DF821	FD406	G1371	DF681
HARLEY D.	FXSB 103 BREAKOUT	1687	15	15	FD219	G1370		DF680	FD406	G1371	DF681
HARLEY D.	FXSB BREAKOUT	1687	15	17	FD219	G1370		DF680			DF681
HARLEY D.	FXST SOFTAIL STANDARD	1687	15	15	FD219	G1370		DF680	FD406	G1371	DF681
HARLEY D.	FLSTF FAT BOY	1690	15		FD219	G1370	1	DF835	FD406	G1371	DF836
HARLEY D.	FLSTFB FAT BOY	1690	15		FD219	G1370	1	DF835	FD406	G1371	DF836
HARLEY D.	FLSTN SOFTAIL DELUXE	1690	15		FD219	G1370	1	DF835	FD406	G1371	DF836
HARLEY D.	FLTRX ROAD GLIDE	1690	15		FD369	G1370	2	DF838	FD369	G1370	DF836
HARLEY D.	FLTRX ROAD GLIDE SPECIAL	1690	15		FD369	G1370	2	DF821	FD369	G1370	DF836
HARLEY D.	FXSB BREAKOUT	1690	15		FD219	G1370	1	DF835	FD406	G1371	DF836
HARLEY D.	FXSB BREAKOUT	1690	15		FD405	G1370	1	DF835	FD406	G1371	DF681
HARLEY D.	FXSB BREAKOUT	1690	15	15							DF681
HARLEY D.	FLDE DELUXE	1745	18		FD219	G1370	1	DF835	FD542	G1371	DF836
HARLEY D.	FLFB FAT BOY 104	1745	18		FD219	G1370	1	DF835	FD542	G1371	DF836
HARLEY D.	FLHC HERITAGE CLASSIC 107	1745	18		FD219	G1370	1	DF835	FD542	G1371	DF836
HARLEY D.	FLHXS CVO STREET GLIDE SPECIAL	1745	18		FD369	G1370	2	DF835	FD369	G1370	DF836
HARLEY D.	FLHXS/FLHXSE STREET GLIDE ANNIVERSARY	1745	18	18			2				DF836
HARLEY D.	FLHXSE CVO STREET GLIDE	1745	18		FD369	G1370	2	DF838	FD369	G1370	DF836
HARLEY D.	FLS SOFTAIL SLIM	1745	18		FD219	G1370	1	DF835	FD542	G1371	DF836
HARLEY D.	FLSB SPORT GLIDE	1745	18		FD219	G1375	1	DF835	FD542	G1370	DF836
HARLEY D.	FLTRXS CVO ROAD GLIDE SPECIAL	1745	18		FD369	G1370	2	DF835	FD369	G1370	DF836
HARLEY D.	FLTRXSE CVO ROAD GLIDE	1745	18		FD369	G1370	2	DF835	FD369	G1370	DF836
HARLEY D.	FXBB STREET BOB	1745	18		FD219	G1370	1	DF835	FD542	G1371	DF836
HARLEY D.	FXBR BREAKOUT 107	1745	18		FD219	G1370	2	DF835	FD542	G1371	DF836
HARLEY D.	FXFBS FAT BOB 107	1745	18		FD219	G1370	1	DF835	FD542	G1371	DF836
HARLEY D.	FXLR LOW RIDER	1745	18		FD219	G1370	1	DF835	FD542	G1371	DF836
HARLEY D.	FXST SOFTAIL ESTANDAR	1745	19		FD219	G1370	1	DF835	FD542	G1371	DF836
HARLEY D.	FLDE DELUXE	1753	18	21	FD369	G1054	1	DF835	FD369	G1370	DF681
HARLEY D.	FLFB FAY BOY	1753	18	20	FD219	G1054	1	DF835	FD542	G1370	DF681
HARLEY D.	FLHC HERITAGE CLASSIC	1753	18	20	FD219	G1054	1	DF835	FD542	G1370	DF681
HARLEY D.	FLHP ROAD KING POLICE	1753	17	18	FD369	G1370	2	DF838	FD369	G1370	DF681
HARLEY D.	FLHR ROAD KING	1753	17	19	FD369	G1370	2	DF838	FD369	G1370	DF681
HARLEY D.	FLHR ROAD KING	1753	20	20	FD369	G1370	2	DF932	FD369	G1370	DF681
HARLEY D.	FLHR ROAD KING	1753	21	22	FD369	G1370	2	DF932	FD369	G1370	DF836
HARLEY D.	FLHRC ROAD KING CLASSIC	1753	17	19	FD369	G1370	2	DF680	FD369	G1370	DF681
HARLEY D.	FLHRXS ROAD KING SPECIAL	1753	17	19	FD369	G1370	2	DF680	FD369	G1370	DF681
HARLEY D.	FLHT ELECTRA GLIDE STANDARD	1753	19	20	FD369	G1370	2	DF838	FD369	G1370	DF681
HARLEY D.	FLHT ELECTRA GLIDE STANDARD	1753	21	22	FD369	G1370	2	DF838	FD369	G1370	DF836
HARLEY D.	FLHTCU ELECTRA GLIDE ULTRA CLASSIC	1753	17	19	FD369	G1370	2	DF838	FD369	G1370	DF681
HARLEY D.	FLHTCUTG TRI GLIDE ULTRA	1753	17	18	FD369	G1370	2	DF835			
HARLEY D.	FLHTK ULTRA LIMITED	1753	17	18	FD369	G1370	2	DF838	FD369	G1370	DF681
HARLEY D.	FLHTK ULTRA LIMITED	1753	20	20	FD369	G1370	2	DF932	FD369	G1370	DF681
HARLEY D.	FLHTK ULTRA LIMITED SHRINE	1753	17	18	FD369	G1370	2	DF838	FD369	G1370	DF681
HARLEY D.	FLHTK ULTRA LIMITED SHRINE	1753	20	20	FD369	G1370	2	DF932	FD369	G1370	DF681
HARLEY D.	FLHTKANV ULTRA LIMITED ANNIVERSARY	1753	18	18	FD369	G1370	2	DF838	FD369	G1370	DF681
HARLEY D.	FLHTKL ULTRA LIMITED LOW	1753	17	18	FD369	G1370	2	DF838	FD369	G1370	DF681
HARLEY D.	FLHTP ELECTRA GLIDE STANDARD POLICE	1753	17	18	FD369	G1370	2	DF838	FD369	G1370	DF681
HARLEY D.	FLHX STREET GLIDE	1753	17	20	FD369	G1370	2	DF838	FD369	G1370	DF681
HARLEY D.	FLHX STREET GLIDE	1753	21	23	FD369	G1370	2	DF838	FD369	G1370	DF681
HARLEY D.	FLHXS STREET GLIDE SPECIAL	1753	18	18	FD369	G1370	2	DF680	FD369		DF681
HARLEY D.	FLHXSANV STREET GLIDE ANNIVERSARY	1753	23	23	FD369	G1370	2	DF838	FD369	G1370	DF681
HARLEY D.	FLHXSANV STREET GLIDE SPECIAL ANNIVERSARY	1753	18	18	FD369	G1370	2	DF680	FD369	G1370	DF681
HARLEY D.	FLRT FREEE Wheeler TRIKE	1753	17	18	FD369	G1370	2	DF835			

MOTORCYCLES LIST

MARCA	MODELO	CC	FROM	TO	FD FRONT	COMP	Nº	DF FRONT	FD REAR	COMP	DF REAR
HARLEY D.	FLSL SLIM	1753	18	21	FD219	G1370	2	DF680	FD542	G1370	DF681
HARLEY D.	FLTRK ROAD GLIDE LIMITED	1753	20	20	FD369	G1370	2	DF994	FD369	G1370	DF681
HARLEY D.	FLTRX ROAD GLIDE	1753	17	20	FD369	G1370	2	DF838	FD369	G1370	DF681
HARLEY D.	FLTRX ROAD GLIDE	1753	21	23	FD369	G1370	2	DF838	FD369	G1370	DF681
HARLEY D.	FLTRXS ROAD GLIDE SPECIAL	1753	17	17	FD369	G1370	2	DF838	FD369	G1370	DF681
HARLEY D.	FLTRXS ROAD GLIDE SPECIAL	1753	18	19	FD369	G1370	2	DF680	FD369	G1370	DF681
HARLEY D.	FXBB STREET BOB	1753	18	20	FD219	G1370	2	DF680	FD542	G1370	DF681
HARLEY D.	FXBR BREAKOUT	1753	18	19	FD219	G1370	2	DF680	FD542	G1370	DF681
HARLEY D.	FXFB FAT BOB	1753	18	20	FD219	G1370		DF680	FD542	G1370	DF681
HARLEY D.	FXLR LOW RIDER /I	1753	18	20	FD219	G1370		DF680	FD542	G1370	DF681
HARLEY D.	FXST SOFTAIL STANDARD	1753	20	23	FD219	G1370		DF680	FD542	G1370	DF681
HARLEY D.	CVO SOFTAIL DELUXE	1801	15		FD219	G1370	2	DF835	FD406	G1370	DF836
HARLEY D.	CVO DELUXE BREAKOUT	1802	15	15			1	DF680			
HARLEY D.	FLHXSE CVO STREET GLIDE	1802	15	15	FD369	G1370	2		FD369	G1370	DF681
HARLEY D.	FLS 103 SLIM	1802	15	15	FD219	G1370	2	DF680	FD406	G1371	DF681
HARLEY D.	FLSS SLIM	1802	16	17	FD219	G1370	2	DF680	FD406	G1371	DF681
HARLEY D.	FLSTFS FAT BOY S	1802	16	17	FD219	G1370	2	DF680	FD406	G1371	DF681
HARLEY D.	FLTRUSE CVO ROAD GLIDE	1802	15	15	FD369	G1370	2	DF94	FD369	G1370	DF681
HARLEY D.	FLTRUSE CVO ROAD GLIDE ULTRA	1802	16	16	FD369	G1370	2	DF994	FD369	G1370	DF681
HARLEY D.	FXDLS DYNA LOW RIDER S	1802	16	17	FD405	G1370		DF821	FD406	G1371	DF681
HARLEY D.	FXSE CVO PRO STREET BREAKOUT	1802	16	17	FD219	G1370			FD406	G1371	DF681
HARLEY D.	FLFB FAT BOY 114	1868	18		FD219	G1370	1	DF835	FD542	G1371	DF836
HARLEY D.	FLFBS FAY BOY 114	1868	18	23	FD219	G1054	1	DF835	FD542	G1370	DF681
HARLEY D.	FLFBSANV FAY BOY 114 ANNIVERSARY	1868	18	18	FD219	G1054	1	DF835	FD542	G1370	DF681
HARLEY D.	FLFBSANV FAY BOY 114 ANNIVERSARY	1868	20	23	FD219	G1054	1	DF835	FD542	G1370	DF681
HARLEY D.	FLH REVIVAL	1868	21	21			2	DF835	FD369	G1370	DF681
HARLEY D.	FLHC HERITAGE CLASSIC 114	1868	18		FD219	G1370	1		FD542	G1371	
HARLEY D.	FLHCS HERITAGE CLASSIC 114	1868	18	23	FD219	G1370	1	DF835	FD542	G1370	DF681
HARLEY D.	FLHCSANV HERITAGE CLASSIC 114 ANNIVERSARY	1868	23	23	FD219	G1370	1	DF835	FD542	G1370	DF681
HARLEY D.	FLHCSANV HERITAGE CLASSIC 114 ANNIVERSARY	1868	18	18	FD219	G1370	1	DF835	FD542	G1370	DF681
HARLEY D.	FLHP ROAD KING POLICE	1868	19	20	FD369	G1370	2	DF838	FD369	G1370	DF681
HARLEY D.	FLHP ROAD KING POLICE	1868	21	23	FD369	G1370	2	DF838	FD369	G1370	DF836
HARLEY D.	FLHRXS ROAD KING SPECIAL	1868	20	23	FD369	G1370	2	DF838	FD369	G1370	DF836
HARLEY D.	FLHTCUTG TRI GLIDE ULTRA	1868	19	23	FD369	G1370	2	DF835			
HARLEY D.	FLHTCUTGANV TRI GLIDE ULTRA ANNIVERSARY	1868	18	18	FD369	G1370	2	DF835			
HARLEY D.	FLHTCUTGANV TRI GLIDE ULTRA ANNIVERSARY	1868	23	23	FD369	G1370	2	DF835			
HARLEY D.	FLHTK ULTRA LIMITED	1868	19	19	FD369	G1370	2	DF838	FD369	G1370	DF681
HARLEY D.	FLHTK ULTRA LIMITED	1868	21	23	FD369	G1370	2	DF932	FD369	G1370	DF681
HARLEY D.	FLHTK ULTRA LIMITED SHRINE	1868	19	19	FD369	G1370	2	DF838	FD369	G1370	DF681
HARLEY D.	FLHTK ULTRA LIMITED SHRINE	1868	21	23	FD369	G1370	2	DF932	FD369	G1370	DF681
HARLEY D.	FLHTKANV ULTRA LIMITED ANNIVERSARY	1868	23	23	FD369	G1370	2	DF932	FD369	G1370	DF681
HARLEY D.	FLHTKL ULTRA LIMITED LOW	1868	19	19	FD369	G1370	2	DF838	FD369	G1370	DF681
HARLEY D.	FLHTKSE CVO ULTRA LIMITED	1868	17	17	FD369	G1370	2	DF932	FD369	G1370	DF681
HARLEY D.	FLHTP ELECTRA GLIDE STANDARD POLICE	1868	19	20	FD369	G1370	2	DF838	FD369	G1370	DF681
HARLEY D.	FLHTP ELECTRA GLIDE STANDARD POLICE	1868	21	23	FD369	G1370	2	DF838	FD369	G1370	DF681
HARLEY D.	FLHXS STREET GLIDE SPECIAL	1868	17	17	FD369	G1370	2	DF838	FD369	G1370	DF681
HARLEY D.	FLHXS STREET GLIDE SPECIAL	1868	19	19	FD369	G1370	2	DF835	FD369	G1370	DF681
HARLEY D.	FLHXS STREET GLIDE SPECIAL	1868	20	20	FD369	G1370	2	DF838	FD369	G1370	DF681
HARLEY D.	FLHXS STREET GLIDE SPECIAL	1868	21	23	FD369	G1370	2	DF838	FD369	G1370	DF681
HARLEY D.	FLHXSE CVO STREET GLIDE	1868	16	17	FD369	G1370	2		FD369	G1370	DF681
HARLEY D.	FLRT FREEEWEELER TRIKE	1868	19	23	FD369	G1370	2	DF835			
HARLEY D.	FLTRK ROAD GLIDE LIMITED	1868	21	23	FD369	G1370	2	DF994	FD369	G1370	DF681
HARLEY D.	FLTRT ROAD GLIDE 3	1868	23	23	FD369	G1370	2	DF835			
HARLEY D.	FLTRXS ROAD GLIDE SPECIAL	1868	20	20	FD369	G1370	2	DF680	FD369	G1370	DF681
HARLEY D.	FLTRXS ROAD GLIDE SPECIAL	1868	21	23	FD369	G1370	2	DF838	FD369	G1370	DF836
HARLEY D.	FLTRXSANV ROAD GLIDE LIMITED	1868	23	23	FD369	G1370	2	DF838	FD369	G1370	DF836
HARLEY D.	FXBBS STREET BOB 114	1868	21	21	FD219		2	DF680	FD542		DF681
HARLEY D.	FXBBS STREET BOB 114	1868	22	22	FD219		2	DF835	FD542		DF681
HARLEY D.	FXBBS STREET BOB 114	1868	23	23	FD219		2	DF680	FD542		DF681
HARLEY D.	FXBRS BREAKOUT 114	1868	18		FD219	G1370	1	DF835	FD542	G1371	
HARLEY D.	FXBRS BREAKOUT 114	1868	18	22	FD219	G1370	2	DF680	FD542	G1370	DF681
HARLEY D.	FXBRSANV BREAKOUT 114 ANNIVERSARY	1868	18	18	FD219	G1370	2	DF680	FD542	G1370	DF681
HARLEY D.	FXDRS 114	1868	19	20	FD219	G1054		DF680	FD542	G1370	DF681
HARLEY D.	FXFBS FAT BOB 114	1868	18		FD219	G1370	1	DF835	FD542	G1371	
HARLEY D.	FXFBS FAT BOB 114	1868	18		FD219	G1370		DF835	FD542	G1371	DF681

FD front FD rear Brake pads reference Front-Rear Comp. Brake pads compound DF front DF rear Brake disc reference Front-Rear Nº Front brake discs quantity

MOTORCYCLES LIST

MARCA	MODELO	CC	FROM	TO	FD FRONT	COMP	Nº	DF FRONT	FD REAR	COMP	DF REAR
HARLEY D.	FXLRS LOW RIDER S	1868	20	22	FD219	G1370		DF680	FD542	G1370	DF681
HARLEY D.	SPORT GLIDE	1868	18		FD219	G1370	2		FD542	G1371	
HARLEY D.	FLHTCUTGSE CVO TRI GLIDE	1917	20	20	FD369	G1370	2	DF838			
HARLEY D.	FLHTCUTGSE CVO TRI GLIDE ULTRA	1917	21	22	FD369	G1370	2	DF838			
HARLEY D.	FLHTKSE ANV CVO ULTRA LIMITED ANNIVERSARY	1917	18	18	FD369	G1370	2	DF932	FD369	G1370	DF681
HARLEY D.	FLHTKSE CVO ULTRA LIMITED	1917	18	18	FD369	G1370	2	DF932	FD369	G1370	DF681
HARLEY D.	FLHTKSE CVO ULTRA LIMITED	1917	19	20	FD369	G1370	2	DF838	FD369	G1370	DF681
HARLEY D.	FLHTKSE CVO ULTRA LIMITED	1917	21	21	FD369	G1370	2	DF838	FD369	G1370	DF681
HARLEY D.	FLHXSE CVO STREET GLIDE	1917	21	22	FD369	G1370	2	DF835	FD369	G1370	DF681
HARLEY D.	FLHXSE CVO STREET GLIDE W/ TURBINE WHEEL	1917	18	20	FD369	G1370	2	DF680	FD369	G1370	DF681
HARLEY D.	FLHXST STREET GLIDE SPECIAL ST	1917	22	23	FD369	G1370	2	DF838	FD369	G1370	DF681
HARLEY D.	FLTRKSE CVO ROAD GLIDE LIMITED	1917	22	22	FD369	G1370	2	DF838	FD369	G1370	DF681
HARLEY D.	FLTRKSEANV CVO ROAD GLIDE LTD ANNIVERSARY	1917	23	23	FD369	G1370	2	DF838	FD369	G1370	DF681
HARLEY D.	FLTRXSE CVO ROAD GLIDE	1917	21	22	FD369	G1370	2	DF835	FD369	G1370	DF836
HARLEY D.	FLTRXSE CVO ROAD GLIDE W/ TURBINE WHEEL	1917	18	20	FD369	G1370	2	DF680	FD369	G1370	DF681
HARLEY D.	FLTRXST ROAD GLIDE SPECIAL ST	1917	22	23	FD369	G1370	2	DF838	FD369	G1370	DF681
HARLEY D.	FXBR BREAKOUT	1917	23	23	FD219	G1370	2	DF680	FD542	G1370	DF681
HARLEY D.	FXLRS LOW RIDER S	1917	23	23	FD219	G1370		DF680	FD542	G1370	DF681
HARLEY D.	FXLRST LOW RIDER ST	1917	22	23	FD219	G1370		DF680	FD542	G1370	DF681
HARLEY D.	FXRST LOW RIDER EL DIABLO	1917	22	22	FD219	G1370		DF680	FD542	G1370	DF681
HARLEY D.	FLHTKSE CVO LIMITED	1923	21		FD369	G1370	2		FD369	G1370	
HARLEY D.	FLHXSE CVO STREET GLIDE	1923	21		FD369	G1370	2		FD369	G1370	
HARLEY D.	FLTRXSE CVO ROAD GLIDE	1923	21		FD369	G1370	2	DF994	FD369	G1370	
HARLEY D.	TOURING CRUISER	1923	23		FD219	G1375	2	DF901	FD340	G1371	DF724
HARLEY D.	ELW 2XAE LIVEWIRE	EV	20	20	FD475	G1054	2	DF838			
HARLEY D.	LIVE WIRE		20	22	FD475	G1375	2	DF838	FD220	G1371	
INDIAN M.	SCOUT SIXTY	999	16		FD068	G1370	1	DF518	FD336	G1397	DF518
INDIAN M.	SCOUT	1130	15	16			1	DF518	FD336	G1397	DF518
INDIAN M.	SCOUT BOBBER	1130	18	21	FD172	G1370	1	DF518	FD165	G1371	DF518
INDIAN M.	SCOUT BOBBER TWENTY	1130	19		FD172	G1370	1	DF518	FD165	G1371	DF518
INDIAN M.	SCOUT FTR	1130	18	24	FD373	G1370	1		FD165	G1371	
INDIAN M.	SCOUT SIXTY	1130	18		FD172	G1370	1	DF518	FD165	G1371	DF518
INDIAN M.	FTR 1200	1200	19	24	FD475	G1375	2	DF902	FD220	G1371	
INDIAN M.	FTR 1200 RALLY	1200	20	24	FD475	G1375	2	DF902	FD220	G1371	
INDIAN M.	FTR 1200 S	1200	19	24	FD475	G1375	2	DF902	FD220	G1371	
INDIAN M.	FTR R CARBON	1200	21	24	FD475	G1375	2	DF902	FD220	G1371	
INDIAN M.	FTR X RSD SUPER HOOLIGAN	1200	24		FD475	G1375	2	DF902	FD220	G1371	
INDIAN M.	SCOUT	1200	18	23	FD172	G1370	1	DF518	FD165	G1397	DF518
INDIAN M.	CHALLENGER DARK HORSE	1768	21		FD475	G1375	2	DF707	FD140	G1371	
INDIAN M.	CHALLENGER LIMITED	1768	21		FD475	G1375	2	DF707	FD140	G1371	
INDIAN M.	CHALLENGER	1800	20		FD475	G1375	2	DF707	FD475	G1375	DF472
INDIAN M.	CHIEF DARK HORSE	1811	16	20	FD331	G1370	2	DF472	FD140	G1054	DF472
INDIAN M.	CHIEFTAIN DARK HORSE	1811	16	20	FD331	G1370	2	DF472	FD140	G1054	DF472
INDIAN M.	ROADMASTER	1811	15	20	FD331	G1370	2	DF472	FD140	G1054	DF472
INDIAN M.	SPRINGFIELD	1811	16	20	FD331	G1370	2	DF472	FD140	G1054	DF472
INDIAN M.	CHIEF BOBBER DARK HORSE	1890	21		FD331	G1370	1	DF472	FD140	G1371	DF472
INDIAN M.	CHIEF DARK HORSE	1890	21		FD331	G1370	1	DF472	FD140	G1371	DF472
INDIAN M.	CHIEFTAIN DARK HORSE	1890	21		FD331	G1370	2		FD140	G1371	
INDIAN M.	CHIEFTAIN LIMITED	1890	21		FD331	G1370	2	DF902	FD140	G1371	
INDIAN M.	ROADMASTER	1890	21		FD331	G1370	2		FD140	G1371	
INDIAN M.	ROADMASTER DARK HORSE	1890	21		FD331	G1370	2		FD140	G1371	
INDIAN M.	ROADMASTER LIMITED	1890	21		FD331	G1370	2		FD140	G1371	
INDIAN M.	SPRINGFIELD	1890	21		FD331	G1370	2		FD140	G1371	
INDIAN M.	SPRINGFIELD DARK HORSE	1890	21		FD331	G1370	2		FD140	G1371	
INDIAN M.	SUPER CHIEF LIMITED	1890	21		FD331	G1370	2		FD140	G1371	DF472
VICTORY	OCTANE	1200	17		FD172	G1370	1		FD165	G1054	
VICTORY	CROSS COUNTRY 8 BALL	1731	15		FD331	G1370	2	DF472	FD140	G1054	DF472
VICTORY	GUNNER	1731	15		FD331	G1370	1	DF472	FD172	G1370	DF472
VICTORY	HIGH BALL	1731	15		FD331	G1370	2	DF472	FD172	G1370	DF472
VICTORY	JUDGE	1731	15		FD331	G1370	1	DF472	FD140	G1370	DF472
VICTORY	MAGNUM	1731	15		FD331	G1370	1	DF472	FD140	G1370	DF472
VICTORY	MAGNUM X1	1731	17		FD331	G1370	1	DF472	FD140	G1370	DF472
VICTORY	VISION	1731	16		FD205	G1370	1	DF472	FD140	G1054	DF472
VICTORY	EMPULSE TT		16		FD176	G1370	2	DF172	FD165	G1371	

BRAKE DISCS REFERENCES

GALFER **DF 472 FLV** **OE**



øext. 298 mm
øint. 64
5,0
10,5

1.736 gr

GALFER **DF 679 V** **OE**



øext. 292 mm
øint. 50,5
5,0

1.678 gr

GALFER **DF 680 W** **OE**



øext. 292 mm
øint. 56
5,0

1.538 gr

GALFER **DF 472 FLW** **OE**

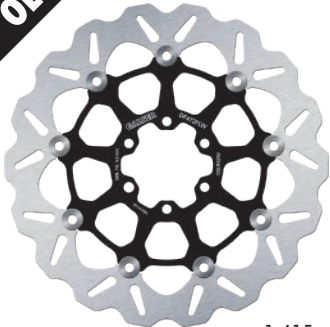

øext. 298 mm
øint. 64
5,0
10,5

1.415 gr

GALFER **DF 679 W** **OE**



øext. 292 mm
øint. 50,5
5,0

1.491 gr

GALFER **DF 680 FLV** **OE**



øext. 292 mm
øint. 56
5,0

1.866 gr

GALFER **DF 472 FLQ**

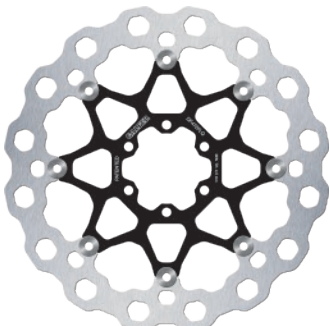

øext. 298 mm
øint. 64
5,0
10,5

1.386 gr

GALFER **DF 679 FLV** **OE**



øext. 292 mm
øint. 50,5
5,0

1.880 gr

GALFER **DF 680 CWU*** **OE**



øext. 292 mm
øint. 56
5,0

1.383 gr

* L (Black bright) - LC (Black contrast)
R (Red) - B (Blue) - Y (Gold) - N (Orange)

GALFER **DF 518 W** **OE**



øext. 298 mm
øint. 64
5,0

1.648 gr

GALFER **DF 679 FLW** **OE**

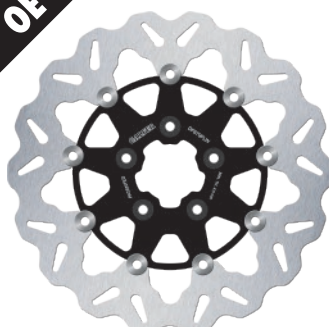

øext. 292 mm
øint. 50,5
5,0

1.510 gr

GALFER **DF 680 RH** **OE**



øext. 292 mm
øint. 56
5,0

1.415 gr

GALFER **DF 518 FLW** **OE**



øext. 298 mm
øint. 64
5,0

1.637 gr

GALFER **DF 680 V** **OE**



øext. 292 mm
øint. 56
5,0

1.787 gr

GALFER **DF 680 FRH** **OE**



øext. 292 mm
øint. 56
5,0

1.667 gr

BRAKE DISCS REFERENCES

GALFER	
DF 680 Q	
 292 mm	
 56	
 5,0	
	
	
GALFER	
DF 680 FLQ	
 292 mm	
 56	
 5,0	
	
	
GALFER	
DF 680 CWSX*	
 330 mm	
 56	
 5,0	
	
	
GALFER	
DF 681 V	
 292 mm	
 56	
 6,4	
	
	
GALFER	
DF 681 W	
 292 mm	
 56	
 6,4	
	
	



1.286 gr

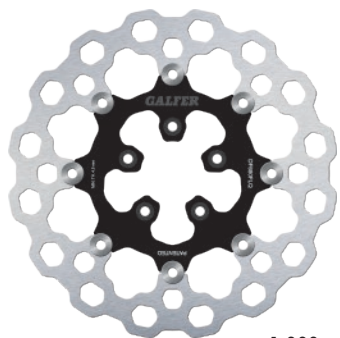

1.393 gr

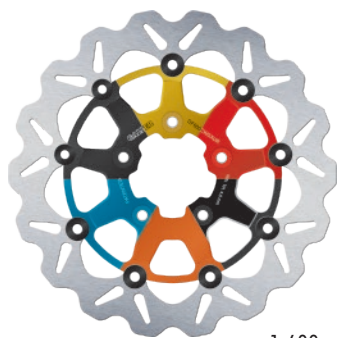

1.600 gr



2.159 gr



1.951 gr

GALFER	
DF 681 FLV	OE
 292 mm	
 56	
 5,0	
	
	
GALFER	
DF 681 CWU*	OE
 292 mm	
 56	
 5,0	
	
	
GALFER	
DF 681 RH	OE
 292 mm	
 56	
 6,4	
	
	
GALFER	
DF 681 FRH	OE
 292 mm	
 56	
 5,0	
	
	
GALFER	
DF 681 Q	
 292 mm	
 56	
 6,4	
	
	



1.853 gr

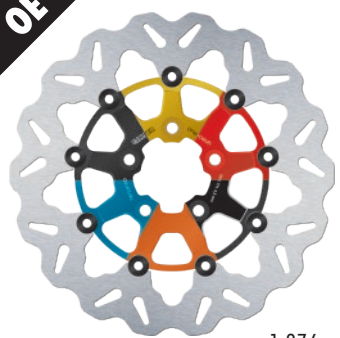

1.376 gr

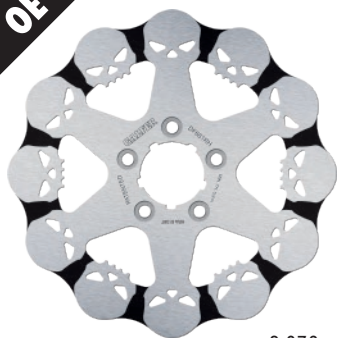

2.078 gr

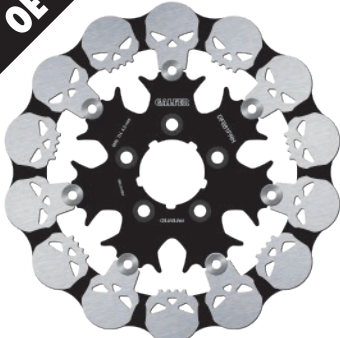

1.515 gr



1.658 gr

GALFER	
DF 682 V	OE
 292 mm	
 50,5	
 5,0	
	
	
GALFER	
DF 682 W	OE
 292 mm	
 50,5	
 5,0	
	
	
GALFER	
DF 682 RH	OE
 292 mm	
 50,5	
 5,0	
	
	
GALFER	
DF 692 CW	OE
 310 mm	
 58	
 5,0	
 17,0	
	
GALFER	
DF 724 V	OE
 260 mm	
 56	
 6,0	
	
	



1.760 gr



1.525 gr



1.427 gr



1.404 gr



1.792 gr

BRAKE DISCS REFERENCES

GALFER **DF 724 W** **OE**



øext. 260 mm
øint. 56
6,0

1.444 gr

GALFER **DF 821 PW** **OE**



øext. 300 mm
øint. 172
5,0

1.020 gr

GALFER **DF 823 PV** **OE**



øext. 292 mm
øint. 172
5,0

1.162 gr

GALFER **DF 724 FLW** **OE**



øext. 260 mm
øint. 56
6,0

1.533 gr

GALFER **DF 821 PQ** **OE**



øext. 300 mm
øint. 172
5,0

873 gr

GALFER **DF 823 PW** **OE**



øext. 292 mm
øint. 172
5,0

1.057 gr

GALFER **DF 724 RH** **OE**

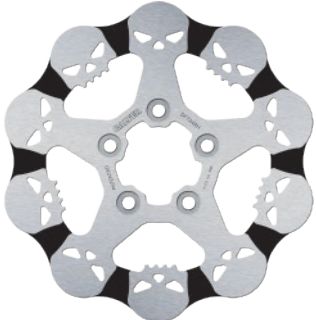

øext. 260 mm
øint. 56
6,0

1.450 gr

GALFER **DF 822 FLV** **OE**



øext. 300 mm
øint. 101,5
5,6
6,3

1.774 gr

GALFER **DF 824 FLV** **OE**



øext. 292 mm
øint. 101,5
5,6

1.810 gr

GALFER **DF 724 Q** **OE**



øext. 260 mm
øint. 56
6,0

1.286 gr

GALFER **DF 822 FLW** **OE**



øext. 300 mm
øint. 101,5
5,6
6,3

1.572 gr

GALFER **DF 824 FLW** **OE**



øext. 292 mm
øint. 101,5
5,6

1.686 gr

GALFER **DF 821 PV** **OE**



øext. 300 mm
øint. 172
5,0

1.122 gr

GALFER **DF 822 FLQ** **OE**



øext. 300 mm
øint. 101,5
5,6
6,3

1.493 gr

GALFER **DF 834 FLW** **OE**



øext. 300 mm
øint. 144
5,0

1.350 gr

BRAKE DISCS REFERENCES

GALFER **DF 835 V** **OE**



øext. 300 mm
øint. 56
5,0

1.781 gr

GALFER **DF 835 W** **OE**



øext. 300 mm
øint. 56
5,0

1.650 gr

GALFER **DF 835 FLV** **OE**



øext. 300 mm
øint. 56
5,0

1.940 gr

GALFER **DF 835 CWU*** **OE**



øext. 300 mm
øint. 56
5,0

* L (Black bright) - LC (Black contrast)
R (Red) - B (Blue) - Y (Gold) - N (Orange)

1.517 gr

GALFER **DF 835 RH** **OE**



øext. 300 mm
øint. 56
5,0

1.700 gr

GALFER **DF 835 FRH** **OE**

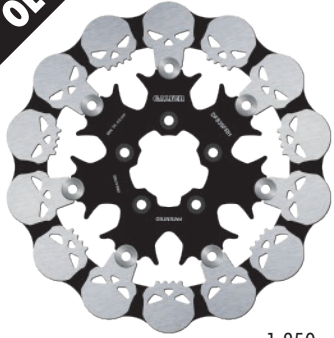

øext. 300 mm
øint. 56
5,0

1.850 gr

GALFER **DF 835 Q** **OE**



øext. 300 mm
øint. 56
5,0

1.323 gr

GALFER **DF 835 FLQ** **OE**

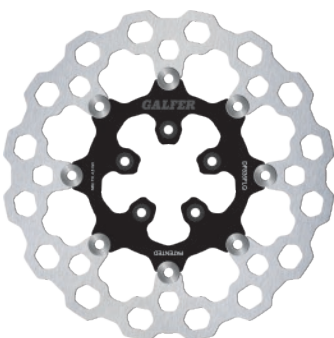

øext. 300 mm
øint. 56
5,0

1.430 gr

GALFER **DF 835 FLQS** **OE**



øext. 320 mm
øint. 56
5,0

1.692 gr

GALFER **DF 835 FLQSX** **OE**



øext. 330 mm
øint. 56
5,0

1.776 gr

GALFER **DF 836 FLV** **OE**

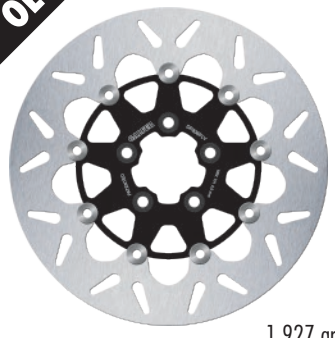

øext. 300 mm
øint. 56
5,0

1.927 gr

GALFER **DF 836 CWU*** **OE**



øext. 300 mm
øint. 56
5,0

* L (Black bright) - LC (Black contrast)
R (Red) - B (Blue) - Y (Gold) - N (Orange)

1.510 gr

GALFER **DF 836 RH** **OE**



øext. 300 mm
øint. 56
5,0

1.700 gr

GALFER **DF 836 FRH** **OE**

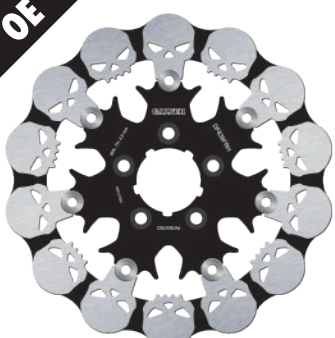

øext. 300 mm
øint. 56
5,0

1.850 gr

GALFER **DF 836 Q** **OE**



øext. 300 mm
øint. 56
5,0

1.323 gr

BRAKE DISCS REFERENCES

GALFER

DF 836 FLQ

øext. 300 mm
øint. 56

5,0

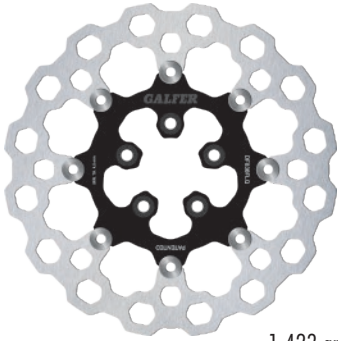

1.423 gr

GALFER

DF 838 QSX

øext. 330 mm
øint. 138,5

5,0

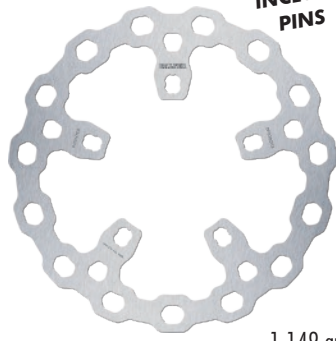

1.149 gr

INCLUDE PINS

GALFER

DF 996 W

øext. 260 mm
øint. 135

5,0





921 gr

OE

GALFER

DF 838 V

øext. 300 mm
øint. 138,5

5,0





1.415 gr

INCLUDE PINS

OE

GALFER

DF 932 W

øext. 300 mm
øint. 124,5

5,0





1.262 gr

OE

GALFER

DF 996 Q

øext. 260 mm
øint. 135

5,0

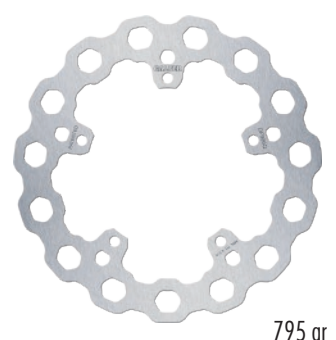

795 gr

GALFER

DF 838 W

øext. 300 mm
øint. 138,5

5,0





1.287 gr

INCLUDE PINS

OE

GALFER

DF 994 W

øext. 300 mm
øint. 124

5,0





1.244 gr

OE

GALFER

DF 838 Q

øext. 300 mm
øint. 138,5

5,0

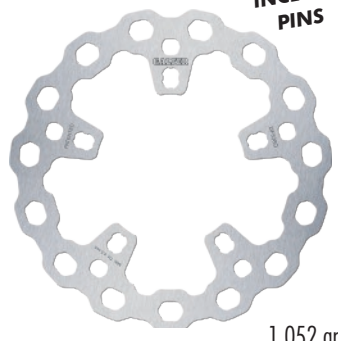

1.052 gr

INCLUDE PINS

GALFER

DF 995 W

øext. 320 mm
øint. 169

6,0





1.483 gr

OE

GALFER

DF 838 QS

øext. 320 mm
øint. 138,5

5,0

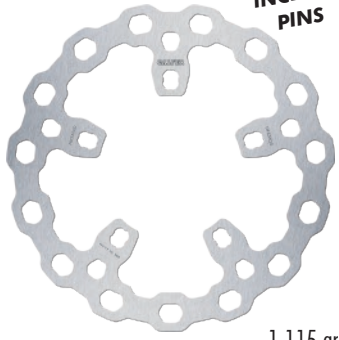

1.115 gr

INCLUDE PINS

GALFER

DF 995 Q

øext. 320 mm
øint. 169

6,0

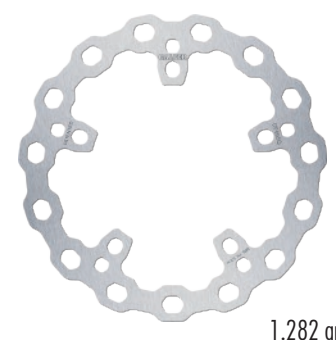

1.282 gr





INDUSTRIAS GALFER S.A.

c/ ctra. de Montmeló, 50 · Circuit de Catalunya
08403 Granollers · BARCELONA (SPAIN)
Tel: +34 93 568 90 90 · Fax: +34 93 568 90 83
info@galfer.es · www.galfermoto.com

GALFER USA

4388 N. Carson Street · Carson City NV 89706
Ph. 805 988 2900 · Fx. 805 988 2948
corporate@galferusa.com
www.galferusa.com

IG ITALIA

Via IV Novembre, 36, 23842 Bosisio Parini (LC)
031 887 0338 | ig.italia@galfer.es



Made in
SPAIN

